

Submersible pumps in stainless steel

-  Filthy water
-  Domestic use
-  Civil use
-  Industrial use



PERFORMANCE RANGE

- Flow rate up to **650 l/min** (39 m³/h)
- Head up to **14 m**

APPLICATION LIMITS

- **5 m** maximum immersion depth
- Maximum liquid temperature **+40 °C**
- Passage of solids:
 - up to **Ø 40 mm** for VX /35-MF
 - up to **Ø 50 mm** for VX /50-MF
- Minimum immersion depth for continuous service:
 - **280 mm** for VX /35-MF
 - **300 mm** for VX /50-MF

CONSTRUCTION AND SAFETY STANDARDS

- **10 m** long power cable
- Float switch for single-phase versions

EN 60335-1
IEC 60335-1
CEI 61-150

EN 60034-1
IEC 60034-1
CEI 2-3



CERTIFICATIONS

Company with management system certified DNV
ISO 9001: QUALITY
ISO 14001: ENVIRONMENT



INSTALLATION AND USE

VX-MF submersible pumps in stainless steel are recommended for draining **filthy water** in domestic, civil and industrial applications, in every case where there are solid bodies in suspension, for example water mixed with mud, groundwater, surface water. They are suitable for draining flooded areas such as cellars, underground car parks, car washes, for emptying cesspools and for sewage disposal.

These pumps distinguish themselves for their reliability, which can be best appreciated under automatic operating conditions in fixed installations.

PATENTS - TRADE MARKS - MODELS

- Patent Pending n. BO2015A000116

OPTIONS AVAILABLE ON REQUEST

- Single-phase pumps without float switch
- Other voltages or 60 Hz frequency

CHARACTERISTIC CURVES AND PERFORMANCE DATA

50 Hz n= 2900 rpm

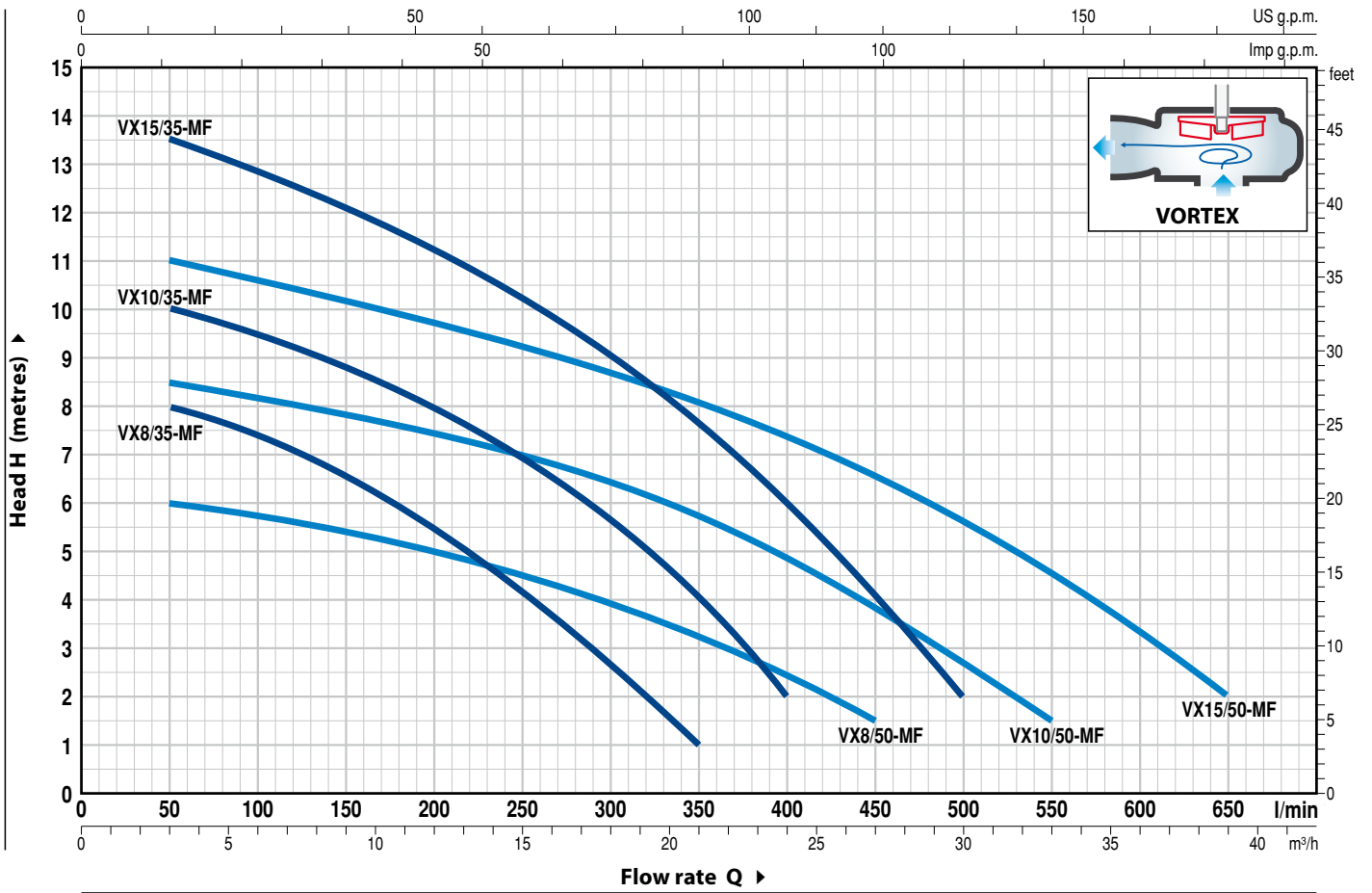

MODEL		POWER (P ₂)		Q	Flow rate														
Single-phase	Three-phase	kW	HP		m ³ /h	0	3	6	12	18	21	24	27	30	33	36	39		
				l/min	0	50	100	200	300	350	400	450	500	550	600	650			
VXm 8/35 -MF	VX 8/35 -MF	0.55	0.75	H metres	9	8	7.5	5.5	2.7	1									
VXm 10/35 -MF	VX 10/35 -MF	0.75	1		11	10	9.5	8	5.7	4	2								
VXm 15/35 -MF	VX 15/35 -MF	1.1	1.5		14	13.5	12.8	11.2	9	7.7	6	4	2						
VXm 8/50 -MF	VX 8/50 -MF	0.55	0.75		6.5	6	5.8	5	4	3.3	2.5	1.5							
VXm 10/50 -MF	VX 10/50 -MF	0.75	1		9	8.5	8.2	7.5	6.5	5.8	5	3.8	2.5	1.5					
VXm 15/50 -MF	VX 15/50 -MF	1.1	1.5		11.5	11	10.5	9.8	8.7	8	7.5	6.5	5.5	4.5	3.5	2			

Q = Flow rate H = Total manometric head

Tolerance of characteristic curves in compliance with EN ISO 9906 Grade 3B.

POS. COMPONENT CONSTRUCTION CHARACTERISTICS

1 PUMP BODY	Precision cast stainless steel AISI 304 with threaded port in compliance with ISO 228/1				
2 BASE	Stainless steel AISI 304				
3 IMPELLER	Stainless steel AISI 304 VORTEX type				
4 MOTOR CASING	Stainless steel AISI 304				
5 MOTOR CASING PLATE	Stainless steel AISI 304				
6 MOTOR SHAFT	Stainless steel AISI 304				
7 SHAFT WITH DOUBLE MECHANICAL SEAL SEPARATED BY AN OIL CHAMBER					
Seal Model	Shaft Diameter	Position	Stationary ring	Rotational ring	Elastomer
MG1-14D SIC	Ø 14 mm	Motor side Pump side	Silicon carbide Silicon carbide	Graphite Silicon carbide	NBR NBR
8 BEARINGS	6203 ZZ / 6203 ZZ				

9 CAPACITOR

Pump	Capacitance	
<i>Single-phase</i>	<i>(230 V or 240 V)</i>	<i>(110 V)</i>
VXm 8/35 -MF	20 µF 450 VL	30 µF - 250 VL
VXm 8/50 -MF		
VXm 10/35-MF		
VXm 10/50-MF		
VXm 15/35-MF	25 µF 450 VL	-
VXm 15/50-MF		

10 ELECTRIC MOTOR

VXm: single-phase 230 V - 50 Hz
with thermal overload protector incorporated into the winding

VX: three-phase 400 V - 50 Hz

- Insulation: class F
- Protection: IP X8

11 POWER CABLE

"H07 RN-F" type
(with Schuko plug for single-phase versions only)

Standard length 10 metres

12 FLOAT SWITCH

(only for single-phase versions)

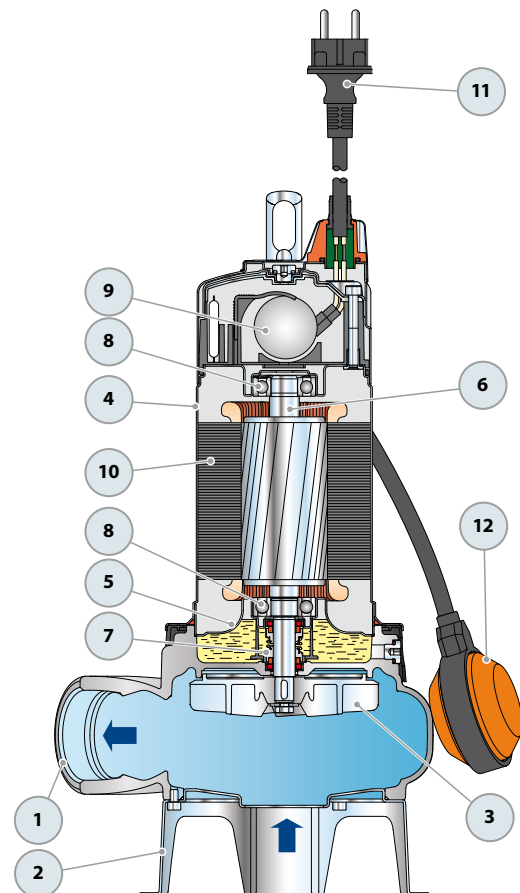

DIMENSIONS AND WEIGHT

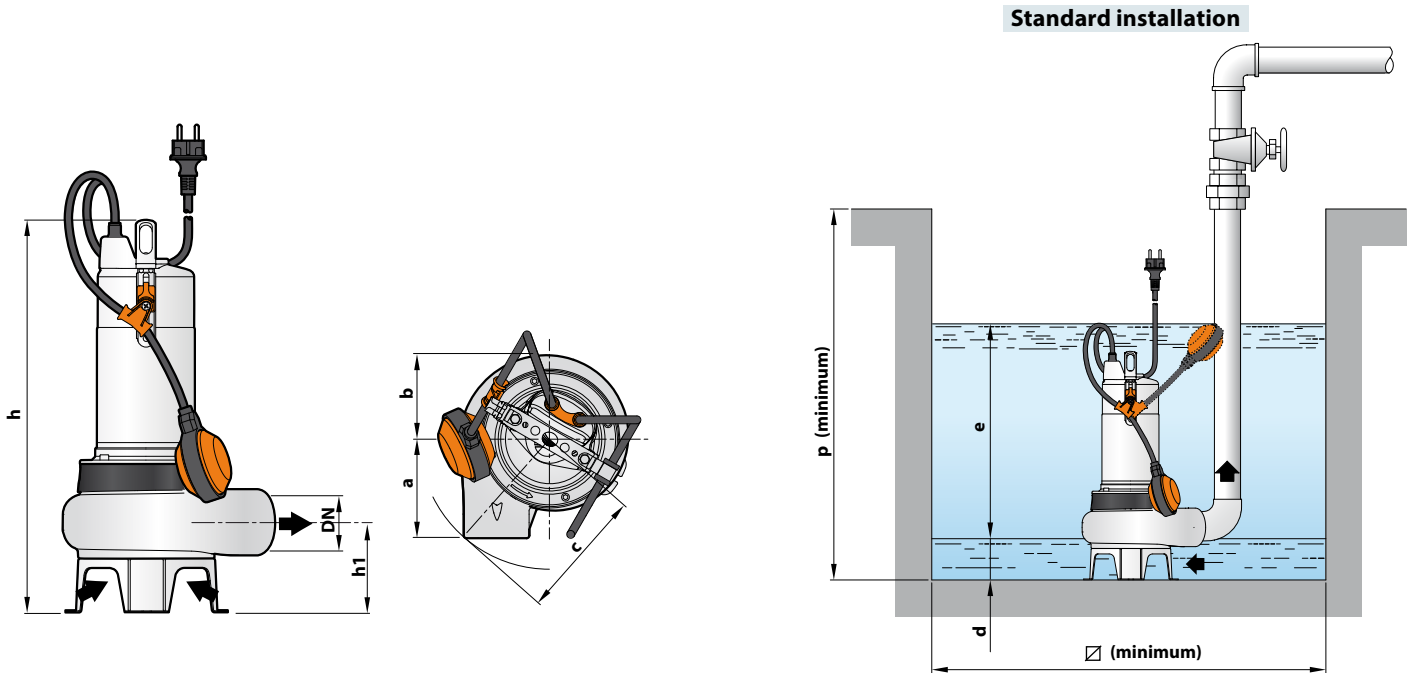

MODEL		PORT DN	Passage of solids	DIMENSIONS mm									kg	
Single-phase	Three-phase			a	b	c	h	h1	d	e	p	∅	1~	3~
VXm 8/35 -MF	VX 8/35 -MF	1½"	∅ 40 mm	107	98	150	406	86	50	variable	500	500	12.9	12.6
VXm 10/35 -MF	VX 10/35 -MF						421						13.7	12.6
VXm 15/35 -MF	VX 15/35 -MF						431						15.0	14.0
VXm 8/50 -MF	VX 8/50 -MF	2"	∅ 50 mm	112	98	150	431	102	60	variable	500	500	13.4	13.1
VXm 10/50 -MF	VX 10/50 -MF						446						14.2	13.1
VXm 15/50 -MF	VX 15/50 -MF						446						15.5	14.5

ABSORPTION

MODEL	VOLTAGE		
	230 V	240 V	110 V
Single-phase	230 V	240 V	110 V
VXm 8/35 -MF	3.5 A	3.4 A	7.0 A
VXm 10/35 -MF	4.8 A	4.6 A	9.6 A
VXm 15/35 -MF	7.4 A	7.1 A	-
VXm 8/50 -MF	3.7 A	3.5 A	7.4 A
VXm 10/50 -MF	5.0 A	4.8 A	10.0 A
VXm 15/50 -MF	7.1 A	6.8 A	-

MODEL	VOLTAGE			
	230 V	400 V	240 V	415 V
Three-phase	230 V	400 V	240 V	415 V
VX 8/35 -MF	3.0 A	1.7 A	2.9 A	1.65 A
VX 10/35 -MF	3.5 A	2.0 A	3.4 A	1.95 A
VX 15/35 -MF	5.2 A	3.0 A	5.0 A	2.9 A
VX 8/50 -MF	3.2 A	1.8 A	3.1 A	1.75 A
VX 10/50 -MF	3.5 A	2.0 A	3.4 A	1.95 A
VX 15/50 -MF	5.2 A	3.0 A	5.0 A	2.9 A

PALLETIZATION

MODEL		GROUPAGE n. pumps	CONTAINER n. pumps
Single-phase	Three-phase		
VXm 8/35 -MF	VX 8/35 -MF	60	80
VXm 10/35 -MF	VX 10/35 -MF	60	80
VXm 15/35 -MF	VX 15/35 -MF	54	72
VXm 8/50 -MF	VX 8/50 -MF	54	72
VXm 10/50 -MF	VX 10/50 -MF	54	72
VXm 15/50 -MF	VX 15/50 -MF	54	72